

### 32 x 32 Element Silicon-Based Thermopile Imaging Array

| <b>Technical Specifications:</b> Specifications apply at 23°C with KBr Window and Nitrogen encapsulating gas |                                   |         |     |                |                         |   |
|--|-----------------------------------|---------|-----|----------------|-------------------------|---|
| Parameter  | Min                               | Typical | Max | Symbol         | Units                   | Comments                                      |
| Active Area size   | .3 x .3                           |         |     | AA             | mm                      | Membrane size, per element.                   |
| Element Area   | .09                               |         |     | A              | mm <sup>2</sup>         |   |
| Number of Junctions  | 28                                |         |     |                |                         | Per element.                                  |
| Number of Pixels   | 1024                              |         |     |                | elements                | Per detector package.                         |
| Output Voltage   |                                   | 27.0    |     | V <sub>s</sub> | μV                      | DC, H=330μW/cm <sup>2</sup> (3)               |
| Responsivity   |                                   | 90.0    |     | R              | V/W                     | DC, R=V <sub>s</sub> /HA (2)                  |
| Resistance   |                                   | 120     |     | R              | kΩ                      |   |
| Temperature Coefficient of Responsivity  |                                   | -.01    |     |                | %/°C                    | Best linear fit, 20° to 40°C (1)              |
| Temperature Coefficient of Resistance  |                                   | .11     |     |                | %/°C                    | Best fit, 0° to 85°C (1)                      |
| Noise Voltage  |                                   | 44      |     | V <sub>n</sub> | nV/√Hz                  | V <sub>n</sub> <sup>2</sup> =4kTR             |
| Noise Equivalent Power   |                                   | .49     |     | NEP            | nW/√Hz                  | DC, NEP= V <sub>n</sub> HA/V <sub>s</sub> (2) |
| Detectivity  |                                   | 6.2     |     | D*             | 10 <sup>7</sup> cm√Hz/W | DC, D*=V <sub>s</sub> /V <sub>n</sub> HVA (2) |
| Time Constant  |                                   | 6       |     | τ              | ms                      | Chopped, -3dB point (1)                       |
| Field of View  | NA                                |         |     | FOV            | Degrees                 | Not Applicable.                               |
| Package size   | .95" x .95"<br>Kyocera PB087700-A |         |     |                | LCC                     | Window size .787" x .787"                     |
| Element Matching   |                                   | NA      |     | M              | %                       |   |
| Element Separation   |                                   | .364    |     |                | mm                      | Center to Center.                             |
| Temperature Reference  |                                   | LM20    |     |                |                         | Active Device.                                |

Notes: (1) Parameter is not 100% tested. 90% of all units meet these specifications. (2) A is detector area in cm<sup>2</sup>.  
(3) Test Conditions: 500K Blackbody source; Detector active surface 10cm from 0.6513cm diameter Blackbody Aperture.

### General Specifications:

- Flat Spectral Response: UV to Far IR
- Window Material: Many filter options in stock
- Encapsulating Gas: Nitrogen
- Operating Temperature Range: -50° to 85°C. Higher temperature range available.
- Multiplexer on chip, in package
- Signal Output: Linear from 10<sup>-6</sup> to .1W/cm<sup>2</sup>
- Maximum Incidence: .1 W/cm<sup>2</sup>
- Self Calibrating

Postal Mail: 7300 Huron River Drive  
Dexter, MI 48130 U.S.A.

Phone: 734-426-3921  
Fax: 734-426-5090

Email: Sales@DexterResearch.com  
Web: www.DexterResearch.com

# Model SA32x32

## Advance Information

### 32 x 32 Element Silicon-Based Thermopile Imaging Array

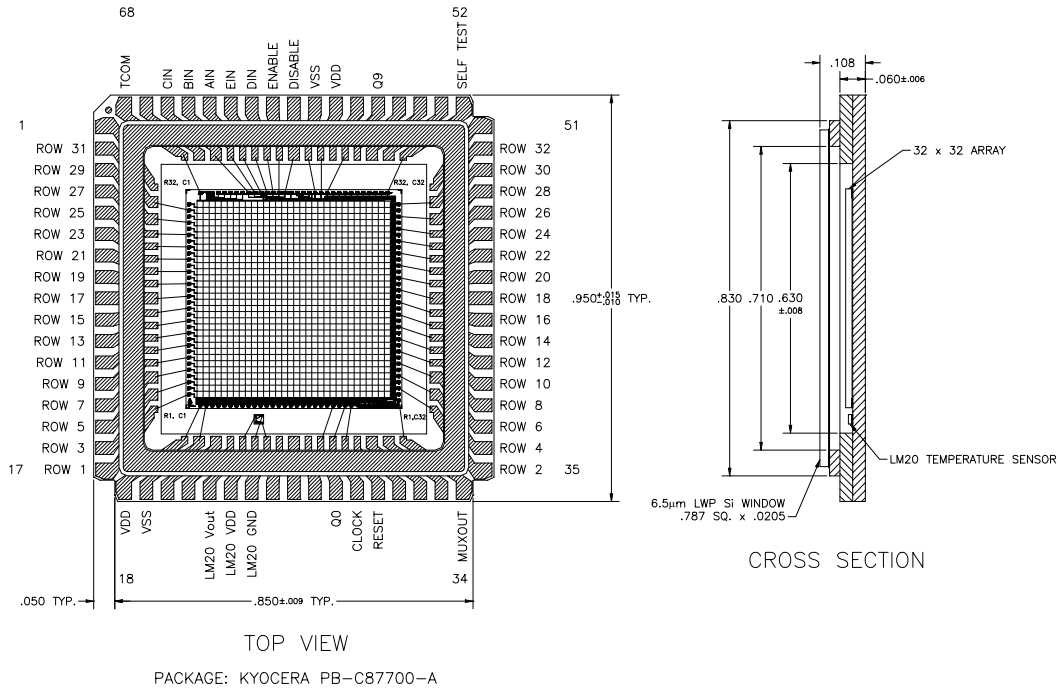

### SA32x32 Array Package

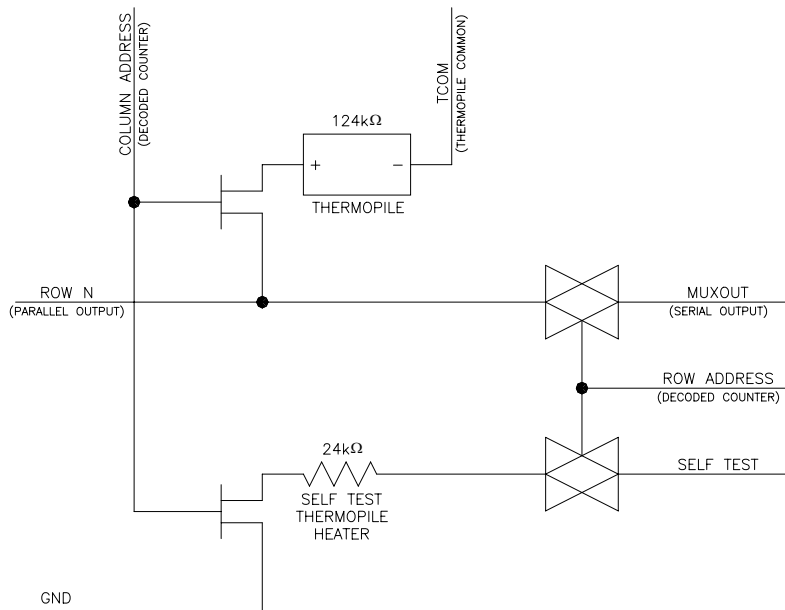

SA32x32 Single Pixel Block Diagram.

Postal Mail: 7300 Huron River Drive  
Dexter, MI 48130 U.S.A.

Phone: 734-426-3921  
Fax: 734-426-5090

Email: Sales@DexterResearch.com  
Web: www.DexterResearch.com



# Model SA32x32

## Advance Information

### 32 x 32 Element Silicon-Based Thermopile Imaging Array

#### SA32x32 User Notes

##### Pin Out Notes

Please refer to SA32x32 assembly drawing 1142 for pin locations.

1. Temperature sensor is a LM20 from National Semiconductor. Output on "LM20 Vout."
2. LM20 voltage supply between "LM20 GND" and "LM20 VDD."
3. Supply voltage is 3.3V to 5V at 50 $\mu$ A - 100 $\mu$ A (DC to 20kHz) between VDD and VSS.
4. TCOM is thermopile common (Negative). ALL 1024 thermopile negative leads are connected to this point.
5. AIN through EIN should be grounded. These are test structure inputs.
6. ENABLE and DISABLE: No connection.
7. Q0 and Q9 are the least and most significant bits respectively of 10-bit counter. For diagnostic use only.
8. The self-test heater is only active when the pixel is selected. The pixel can be heated by supplying a small voltage to SELF-TEST. (0.25V or so)

##### Timing: Parallel Output

Counter RESET is active high. This resets the counter to zero, which selects Column one (C1) on pins ROW 1 to ROW 32 (Positive side of thermopiles).

RESET is low for normal operation. On the negative (downward) edge of the CLOCK the next column is presented on pins ROW 1 to ROW 32.

Counter counts from zero to 1023 (10 bit). The entire array can be clocked out with every 32 clock cycles.

##### Timing: Serial Output

Counter RESET is active high. This resets the counter to zero, which selects Pixel R1, C1 (Row 1, Column 1) on MUXOUT (Positive side of thermopile).

RESET is low for normal operation. On the negative (downward) edge of the CLOCK the next pixel is presented on MUXOUT.

Counter counts from zero to 1023 (10 bit). The entire array can be clocked out with 1024 clock cycles on MUXOUT.