

Infrared Temperature Module

Advanced Information

OVERVIEW:

The Infrared Temperature Module makes non-contact infrared temperature measurements and delivers a radiometrically-calibrated output. The infrared measurement is made using Dexter Research Center's model ST60 thermopile detector with 5µm cut-on LWP silicon filter. Various detector models are available to maximize the performance of your OEM specific application. The module accommodates a regulated supply voltage range of 5 to 15VDC. Radiometric calibration, ambient temperature compensation, and output are accomplished with an on-board micro-controller. The output delivered is a 5V 10-bit PWM or optional LIN Bus.

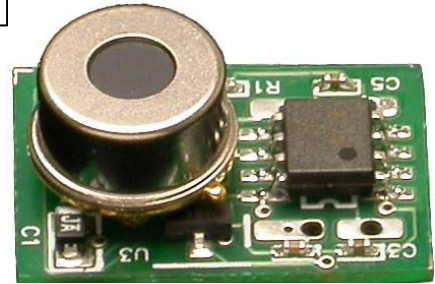

IR Temperature Module
(shown 3X actual size)

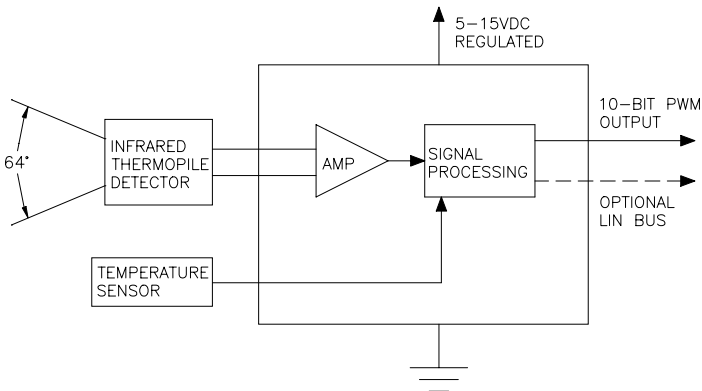

IR TEMPERATURE MODULE: BLOCK DIAGRAM

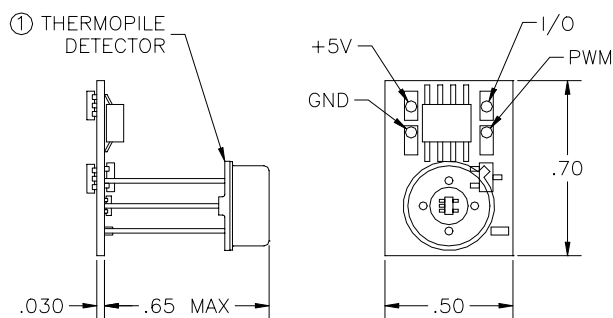

IR TEMPERATURE MODULE

FEATURES

- +/-2°C Accuracy from 0°C to 80°C
- 10 Bit Resolution
- True Radiometric Calibration
- Digital Output: PWM or LIN Bus
- Settable Alarms
- Detector, Window, and Lens options & combinations available
- Dual Sensor Capable
- Supply Voltage 5–15VDC
- Current Draw 5mA
- Automotive grade available

APPLICATIONS

- Household appliance temperature control for microwave ovens, dishwashers, toasters, hair dryers, toaster ovens
- Copier and Laser printer temperature control
- Climate control for industrial, commercial, and residential applications
- Automotive climate control
- Human presence detection
- SARS screening
- Tympanic Thermometer
- Industrial Process control

Postal Mail: 7300 Huron River Drive
Dexter, MI 48130 U.S.A.

Phone: 734-426-3921
Fax: 734-426-5090

Email: Sales@DexterResearch.com
Web: www.DexterResearch.com