



Innovative Photonic Solutions

5310

LED Projectors

KEY FEATURES

- High Intensity
- Long Lifetime
- Multiple Wavelength Options
- 50,000 hour Operation
- Solid State Reliability
- Robust Design
- Excellent Thermal Management



High Intensity Spot Lighting

Using the most sophisticated solid state photon generating technologies, the **5310** series LED Projectors provide extremely high intensities in a robust and reliable product configuration. These compact light projectors are designed to replace simple point-source illumination schemes, surpassing single lamp or fiberoptic solutions in both intensity and lifetime. Available in a wide range of wavelengths, including broadband white and tricolor RGB versions, these devices are configured to run in either continuous or strobed operation. For continuous operation, use with the IT 5000 series current regulated LED controllers. For strobed operation, use the IT 5100 series controllers. Custom wavelengths, cable lengths, and optical configurations available on request.

APPLICATIONS

- Machine Vision
- Biotechnology
- Medical Device
- Color Sorting
- Microscopy
- Pharmaceutical

Detail Drawing

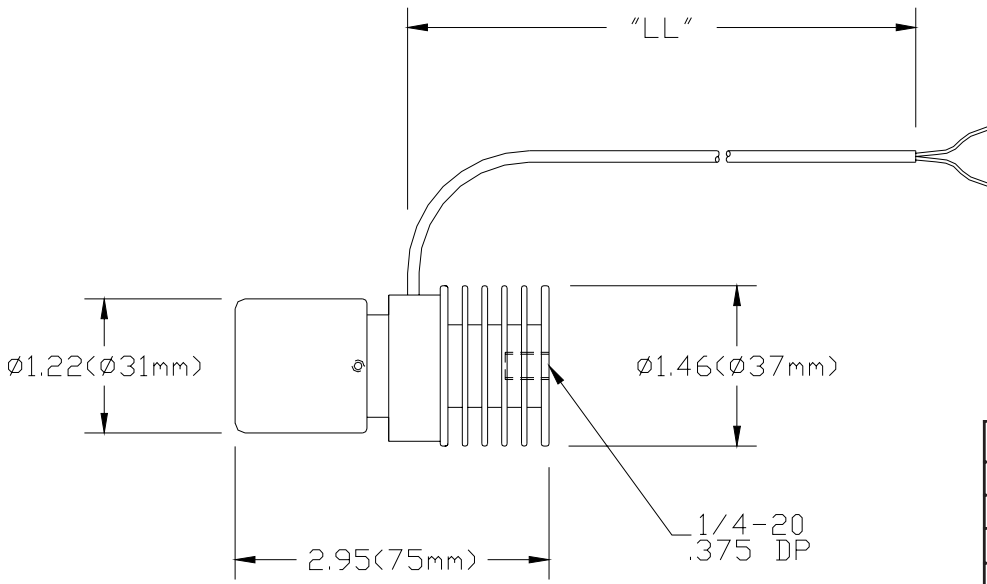

PART NUMBER

5310 - WWW - LL

LL	Length (m)
-01	1m (39")
-02	2m (78")
-03	3m (118")

WWW	Wavelength, color
-455	455 nm, Deep Blue
-470	470 nm, Blue
-505	505 nm, Light Blue
-530	530 nm, Green
-590	590 nm, Amber
-617	617 nm, Orange/Red
-627	627 nm, Red
-WHT	5500K, White

NOTE: Specifications May Change without Notice

DXF File Available

Technical Specifications

Average Lifetime

Continuous: 50,000 Hours
Strobe: 200×10^6 Flashes

Environmental

Temperature: 0 to 35C
Relative Humidity: 0 to 95%

Electronic Controllers

WWW	Continuous	Strobe
-WHT	5010-5XX-CC	5100-5-TTT
-455		
-470		
-505		
-530	5010-3XX-CC	5100-3-TTT
-590		
-617		
-627		

Proudly Distributed By:

Distributor in Israel
www.ILPhotonics.com

Output Comparisons (150mm Distance)

Wavelength	Photometric (lux)	Radiometric (mW/cm ²)	Silimetric (sW/cm ²)*
455 nm	4,400	9.6	3.9
470 nm	12,900	13.3	6.2
505 nm	39,900	8.0	4.1
530 nm	44,100	6.7	3.6
590 nm	22,400	2.8	1.8
617 nm	28,700	9.8	6.1
627 nm	45,500	15.4	11.2
White	31,500	6.9	3.7
150W TH*	18,300	4.0	2.7

* Comparative output of a standard 150W Tungsten Halogen lightsource with 7mm Fiberoptic Lightguide and Focusing Lens (projected to a target 150mm away)

+ Artificial units developed by Illumination Technologies to more accurately predict the relative output signals generated by various illumination devices on silicon based detector systems, including CCD and CMOS cameras. For more detailed information on this topic visit our website and download Tech Note #125 - "Correct Measurement Units"



Innovative Photonic Solutions

Illumination Technologies, Inc.

5 Adler Drive • East Syracuse • New York 13057 USA
TEL: 315-463-4673 • FAX: 315-463-1401 • Toll Free (North America): 800-738-4297
Web: <http://www.illuminationtech.com> • E-mail: info@illuminationtech.com

© 2005 Illumination Technologies