

Features

- ▶ Typical wavelength, 670nm
- ▶ Stabilized optical power 320mW
- ▶ Single supply voltage, 12V DC
- ▶ **APC control**
- ▶ Low power consumption
- ▶ 4Pin connector(standard) or custom
- ▶ Laser class : III b
- ▶ **Active temperature control (TE Cooler & Internal Fan)**
- ◆ **Option : Bracket & Power supply.**

Specification

● Optical

Optical power(mW)	320 (Tc=25°C)
LD power(mW)	500 (Max)
Output Efficiency(%)	64
Wavelength(nm)	670 ±6
Beam Dia(mm)	3.9x1.1
Beam Div(mrad)	<1
Beam Quality	TEM00, M ² <2
Beam intensity Pattern	Gaussian
LD Pin Connection	Case Positive

● Electrical

Operating voltage(DC V)	12 ± 5%
Operating current(mA)	2200(Max)
Laser drive current(mA)	900(Max)
Operating Temp.(°C)	-10 ~ +35
Storage Temp.(°C)	-10 ~ +85

● Mechanical

Weight(g)	395 ± 10
Dimensions(mm)	Φ42 X 180
Housing material	Aluminum

Description

The LM-675HDH series laser diode module combines laser diode technology, quality optics, and sophisticated electronics within a slim and light aluminum anodized housing for variety of applications. This series of modules provides a high-brightness elliptical laser beam in a variety of power up. Applications include a measurement, positioning, lighting, alignment, pointing, switching, leveling, and machine vision etc. Useful in a variety of industrial, and scientific instrumentation, as well as general R&D work.

Drawings

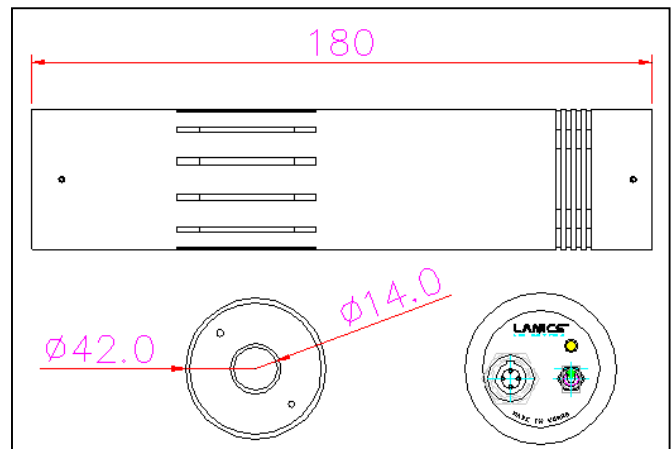

Lanics Co., Ltd.

Room #703, 7F Woolim e-Biz Center
170-5, Guro-dong, Guro-gu, Seoul, 152-050, Korea
TEL : +82-2-2108-2255 FAX : +82-2-2108-2260
E-mail : support@lanics.com
http:// www.lanics.com